

The effect of the lateral distance between the shallow tines of the subsoiler on its draft requirement in a silty clay soil

Shaker H. Aday Murtadha A. Abdul-nabi Dahal R. Ndawii
Agric. Mech. dept., Agric. College, Basrah uinverity, Basrah, Iraq

SUMMARY

A subsoiler of single tine was designed and provided with two shallow tines fixed in front of it. The shallow tines lateral distance between them can be changed. The leg of the subsoiler was provided with foot and the foot was provided with wings at one stage of the experiments. The subsoiler was tested in silty clay soil using four operating depths 30, 40, 50 and 60cm. Three lateral distances were used between the shallow tines 40 , 50, and 60 cm. Wings were also used at one stage of the experiments. The subsoiler combinations are S, S+sh40, S+sh50 and S+sh60.

The draft force of the subsoiler combinations increased as the operating depth increased. The increase was between 15.82 to 17.88kN for four subsoiler combinations when the operating depth increased from 30 to 60cm. The draft force requirement of each centimeter of depth on average is 0.560kN. Using shallow tines with subsoiler increased the draft force requirement and it increased with lateral distance between the shallow tines. The draft force requirement with shallow tines increased as the operating depth increased. The draft force requirement of each centimeter of shallow tines lateral distance for the shallow tines (30cm) is 0.062kN it increased to 0.091kN (91N=9.3kg). Providing the subsoiler with wings increased its draft requirement especially at greater depths. The highest draft requirement was recorded to deeper operating depth (60cm), wider lateral distance (60cm) and with wings on the foot of the subsoiler.

Introduction

The subsoiler is used in the heavy soils which their bulk densities are high as well as it is used where a hard pan exist in the soil [1, 2, 3, 4, 5]. The high bulk density accomplished with low soil porosity which reduces the soil ability to infiltrate the water downward and that resulted in a salt accumulation in the soil profile which reduces the organism's activity. The hard pan existence is severely affecting the soil physical and chemical properties. It prevents the water movement downward and that some time lead to soil logging which stops all the soil biological activities.

However, the subsoiler gives bad performance when unsuitable conditions available. These conditions include suitable moisture content (14-18%) and

the mechanical modification of the subsoiler [4, 5]. When the suitable moisture content is available the soil is easily disturbed with less draft requirement [3, 4]. The mechanical modification of the subsoiler includes the addition of shallow tines in front of the subsoiler and wings to its foot [1, 8 and 9]. The shallow tines disturb the surface soil in the front of the subsoiler leaving the soil at depth to the subsoiler [10 and 11]. The wings causes many cracks at depth develop from their edges up to the soil surface and that increase the volume of disturb soil [4 and 5]. The draft force of the subsoiler, the shallow tines and the wings increases as the operating depth increases and it is higher in the heavy soil than the light soil [11, 12, 13, 14]. The wings draft requirement is higher than the shallow tines because the wings operating in wetter soil, higher shear strength and expose to heavy weight of the soil exists above them [3, 4]. To obtain high field performance the forward angle (rake angle) of the subsoiler leg is 45 to 60° and the wings effective width and inclination angle are 30 to 35cm and 25° respectively [2,5]. The shallow tines depth relative to the subsoiler depth is 50% and 75% in the light and heavy soils respectively [8, 9]. The forward distance of the shallow tines relative to the subsoiler position is 35 to 40cm [9,15]. The lateral distance between the shallow tines has great effect on the subsoiler field performance. Their lateral distance either increases the disturbed area through the interfering with the subsoiler operation or the distance great enough that lead to separate their action from the subsoiler and that reduces the disturbed area and that means the addition of the shallow tines is not useful [4,15]. The forward speed increases the draft force of the subsoiler [16]. This research was conducted to determine the best lateral distance between the shallow tines giving the highest subsoiler field performance. The field performance is evaluated by the draft force, disturbed area, specific resistance and energy utilization efficiency. In this paper the draft force requirement being discussed. The experiment parameters are four operating depths (30, 40, 50 and 60cm), three lateral distances between the shallow tines (40,50 and 60cm) and with and without wings on the subsoiler foot and shallow tines. The experiments were carried out in silty clay soil.

2.0 Materials and methods

2.1 The subsoiler

The subsoiler was designed and manufactured in the agriculture mechanization dept., Agriculture College, Basra University (Figure 1 (A) and (B)). It consists of single tine. The length, width and the thickness of the tine are 95, 12 and 3cm respectively. The leg of the tine is attached to the frame at forward angle (rake angle) of 60°. The tine is provided with foot fixed at the lower end of the leg at angle 120°. The attack angle of the front of the foot is 35°. The foot was provided with wings fixed on both sides at inclination angle

of 25° . The effective width of the wings is 30cm. The subsoiler was provided with two shallow tines. They were fixed at forward distance of 36cm relative to the subsoiler. Their lateral distance (distance between them) can be changed. The subsoiler and the shallow tines were fixed on frame made from square section steel of high carbon. The frame was provided with three attachment points. The lower two points attach to the lower links of the hydraulic system of the tractor and the top one for the third link of the hydraulic system.

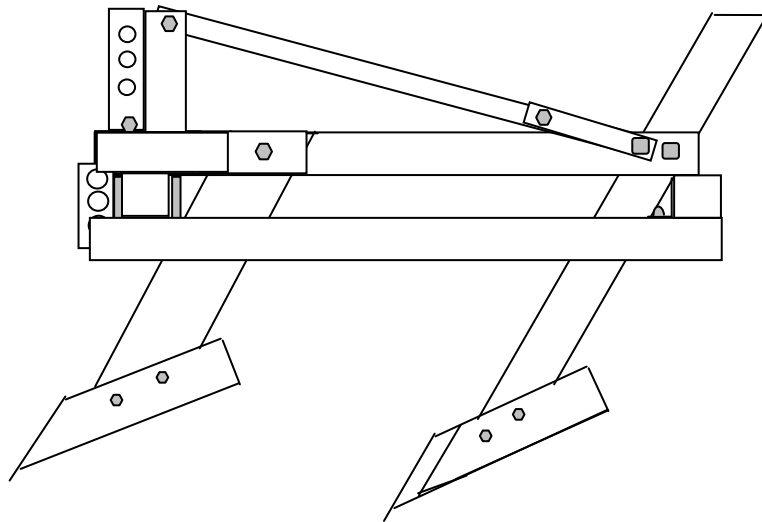

(A) side view

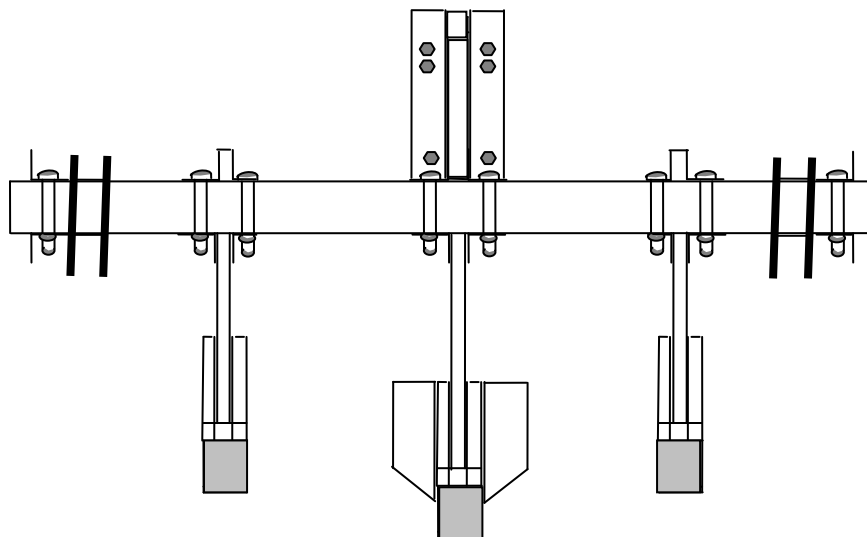

(B) Front view

Figure (1) The subsoiler with shallow tines.

2.2 The draft force measurement

The subsoiler under test was attached to 2WD tractor. This tractor is a Massey-Ferguson (285s) and was used to rise and lower the subsoiler and to be towed by another tractor to measure the draft force. This method was used because the draft force measuring system is of towing type. Another tractor (4WD) was used to tow the tractor- subsoiler combination. The tractor is Massey-Ferguson type (2680). The rate power of the tractor is 96.98kW. In the field the tractor subsoiler combination was towed by tractor 2680 through flexible cable which was attached to the tractor-subsoiler combination from one end and the hydraulic system from the other end. The hydraulic system was linked to the tractor of 2680. The draft force was measured by predetermining the operating depth of the subsoiler (e.g 30cm). The towed tractor gear box left on neutral and the towing tractor gear box was engaged on the first heavy gear ratio. The tractor engine speed was set at speed of 1500rpm. The tractor-subsoiler combination left to move 5m to approach the higher forward speed the readings were taken a long distance of 20m. The number of readings for each run is about 5 to 6. Each run was repeated three times. These runs were conducted for each operating depth, lateral distance between the shallow tines with and without wings. The average of the readings for each run was calculated. The total draft force (the draft force of the tractor-subsoiler combination) was calculated using the following equation which represents the calibration equation of the draft force measuring hydraulic system.

$$F_t = 0.8 + A * X \dots\dots\dots (1)$$

Where F_t = the total draft force of the tractor-subsoiler combination (kN)

A = the internal area of the cylinder of the hydraulic system
(0.0044516 m²).

X = the reading of the hydraulic system in bar (the bar should be changed to kN by multiplying X by 100).

The rolling resistance of the tractor MF 285S of the combination was also measured by towing the tractor-subsoiler combination by the tractor MF2680. The tractor-subsoiler combination was pulled on the surface of field surface and the subsoiler is out of the soil.

The draft force of the subsoiler is calculated from the following equation.

$$F = F_t - R \dots\dots\dots (2)$$

Where F = The draft force of the subsoiler (kN).

R = the rolling resistance of the tractor-subsoiler combination (kN)

Soil physical and mechanical properties

The soil texture was measured by the pipette method as mentioned in [6]. The results are shown in table (1). The bulk density was measured by Core

method for depths 0-10, 10-20, 20-30, 30-40, 40-50 and 50-60cm. The bulk density is calculated by the following equation after the samples were dried in oven at temperature of 105C⁰ for 24hours (Black et al 1983). The results are shown in table (2).

$$\rho_b = \frac{M_s}{V_t} \dots\dots\dots(3)$$

Where ρ_b = the bulk density of soil (Mg.m³)

M_s = mass of the soil (Mg)

V_t = The volume of the soil (m³)

The soil cohesion and angle of internal friction was measured for the soil using the disk method as it is mentioned in (7). The measurements were carried out for depths 0, 20, 30, 40 and 50cm. The soil shear strength was calculated by the following equation.

$$\tau = \frac{3m}{2\pi r^3} \dots\dots\dots(4)$$

τ = soil shear strength (kN.m²)

m = moment of the torque meter (kN.m)

r = radius of the annulus ring.

The results are shown in table (2).

Table(1) soil texture and consistency limits

Liquid limit %	Lower plastic limit %	Clay g.kg ⁻¹	Silt g.kg ⁻¹	Sand g.kg ⁻¹
50.62	27.56	543.6	385	71.6

Table (2): Soil physical and mechanical properties

depth	Moisture content g.g ⁻¹	Bulk density Mgm ⁻³	Cone index Cn kNm ⁻²	Cohesion C kNm ⁻²	Angle of internal Φ °	Friction angle between metal	Adhesion kN.m ⁻²
0-10	0.1329	1.26	1576.44	0.73	32	31.93	0.1592
10-20	0.1426	1.29	2364.68	5.29	30		
20-30	0.1480	1.30	2702.49	15.50	22		
30-40	0.2320	1.35	3040.30	18.85	20		
40-50	0.2690	1.48	2646.19	20.88	31		
50-60	0.2845	1.29	1914.63	13.70	36		

The experiment procedure

The experiments were conducted in silty clay soil. The Randomize Block Design of three factors was used. The factors are subsoiler with and without

wings, three lateral distances between the shallow tines (40, 50 and 60cm) and four operating depths (30, 40, 50 and 60cm), (2x3x4). The results were analyzed using SPSS. The Revised Least Significant Difference (RLSD) was used for comparison between the means at property level of 5%.

3.0 Results and Discussions

3.1 The effect of the operating depth on the subsoiler draft force

Requirement

Figure (2) shows the effect of the operating depths on the draft force requirement of the subsoiler combinations S, S+sh40, S+sh50 and S+sh60. The draft force requirement of the four subsoiler combinations increased as the operating depth increased and that can be related to the increase in the volume of the manipulated soil, soil bulk density, soil strength and the soil moisture content (table 2). The results showed that the draft force increased with adding shallow tines and with increasing the lateral distance between them. For single tine subsoiler (S) the draft force is 13.75kN while for S+sh40, S+sh50 and S+sh60 is 15.19, 17.58 and 18.19 at operating depth of 30cm respectively. The increase in the draft force due to the lateral distance 40, 50 and 60cm is 1.44, 3.83 and 4.44 respectively. The average of the draft force of each centimeter of the lateral distance is 0.062kN.

When the operating depth increased to 60cm the draft force of S, S+sh40, S+sh50 and S+sh60 increased to 29.57, 32.34, 34.31 and 36.07kN respectively. The increase in the draft force due to the operating depth is 15.82, 17.15, 16.73 and 17.88kN respectively, the increase is almost double. This was due to the increase in the soil physical properties as it can be seen from table (2). The results showed that each centimeter of depth required on average 0.56kN and that is greater by nine times of the lateral distance. However, the draft force requirement of one centimeter of lateral distance increased with operating to 0.091kN and related to increase in the soil physical properties, Table (2). The domination of the operating depth on the lateral distance in draft requirement is related to that the increase in the manipulated volume of soil is greater with operating depth than the lateral distance. As well as the soil bulk density, the shear strength and the moisture content are higher at depth than shallow depth where the shallow tines operate. The soil hard pan existed within depth 40-50cm and that can be seen from the high bulk density (1.48Mg.m^3) and that positively affected the draft force requirement of the subsoiler combinations. This depth required higher draft force than depth 50-60cm of bulk density of 1.29Mg.m^3 . The draft force requirement of S, S+sh40, S+sh50 and S+sh60 increased by 7.51, 7.98, 7.01kN when the operating depth increased from 40 to 50cm while it increased only by 3.29, 4.74, 4.68 and 4.94kN when the operating depth increased from 50 to 60cm respectively.

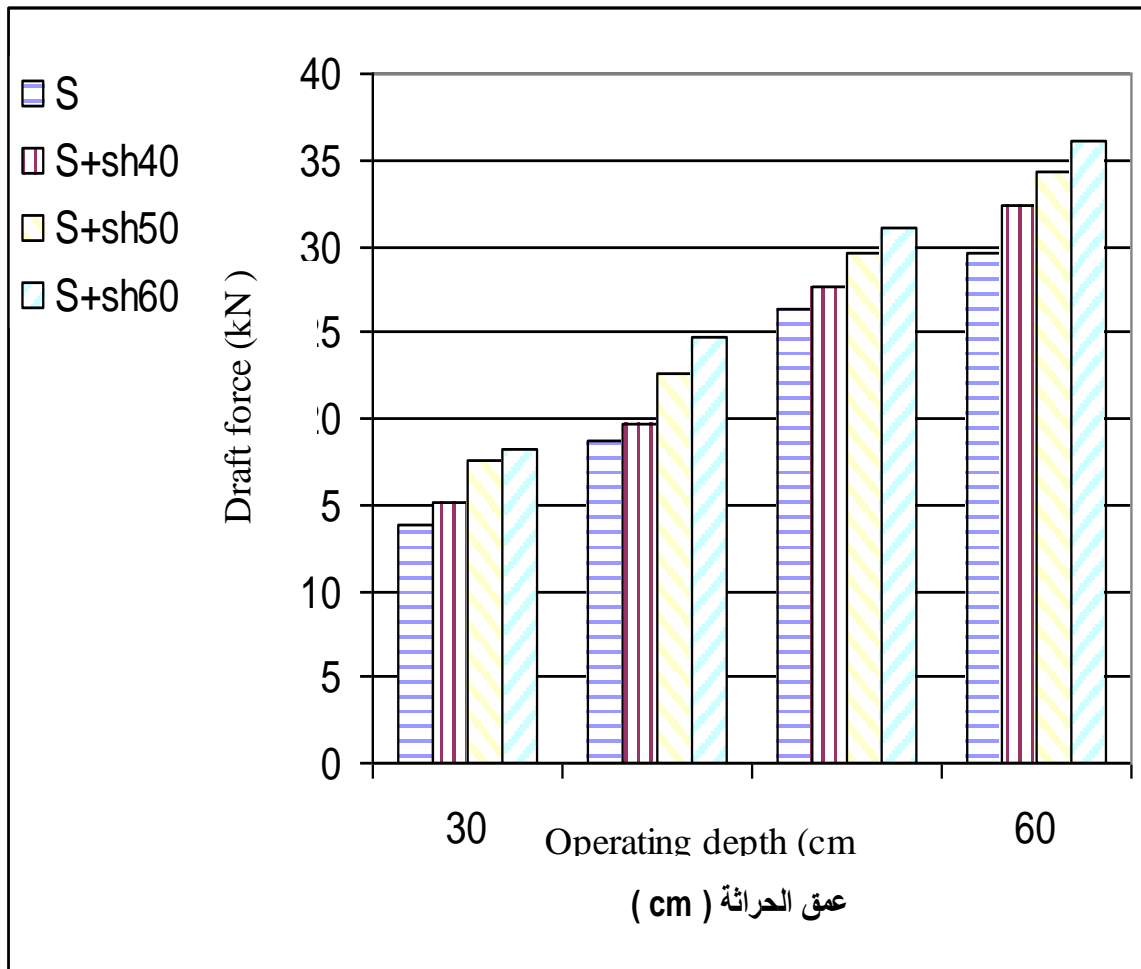

Figure(2): The draft force versus the operating depth for different subsoiler combinations.

3.2 The effect of the lateral distance between shallow tines on the subsoiler draft force requirement.

The aim of increasing the lateral distance between the shallow tines is to increase the cross-sectional width of disturbed soil and therefore increasing the manipulated soil but that required extra draft force. The draft force for the four subsoiler combinations are $S+sh60 > S+sh50 > S+sh40 > S$ (figure 3). The increase in the draft force was limited with increasing the distance between the shallow tines. It was 1.32, 3.35 and 4.85kN for the distance 40, 50 and 60cm for operating depth of 50cm respectively. The difference in the draft requirement between the subsoiler combinations S+sh40, S+sh50 and S+sh60cm dimensioned with operating depth. The draft force of S+sh40, S+sh50 and S+sh60cm increased by 17.15, 16.74 and 17.88kN when the operating depth increased from 30 to 60cm. The reason was that when the

operating depth increased the subsoiler combinations manipulate greater volume of soil, however, with narrow lateral distance (40cm) the soil could not pass easily through the gap between the two shallow tines and that resulted in accumulation of the soil in front the subsoiler which increased the draft force requirement. This problem is limited with lateral distance of 50cm.

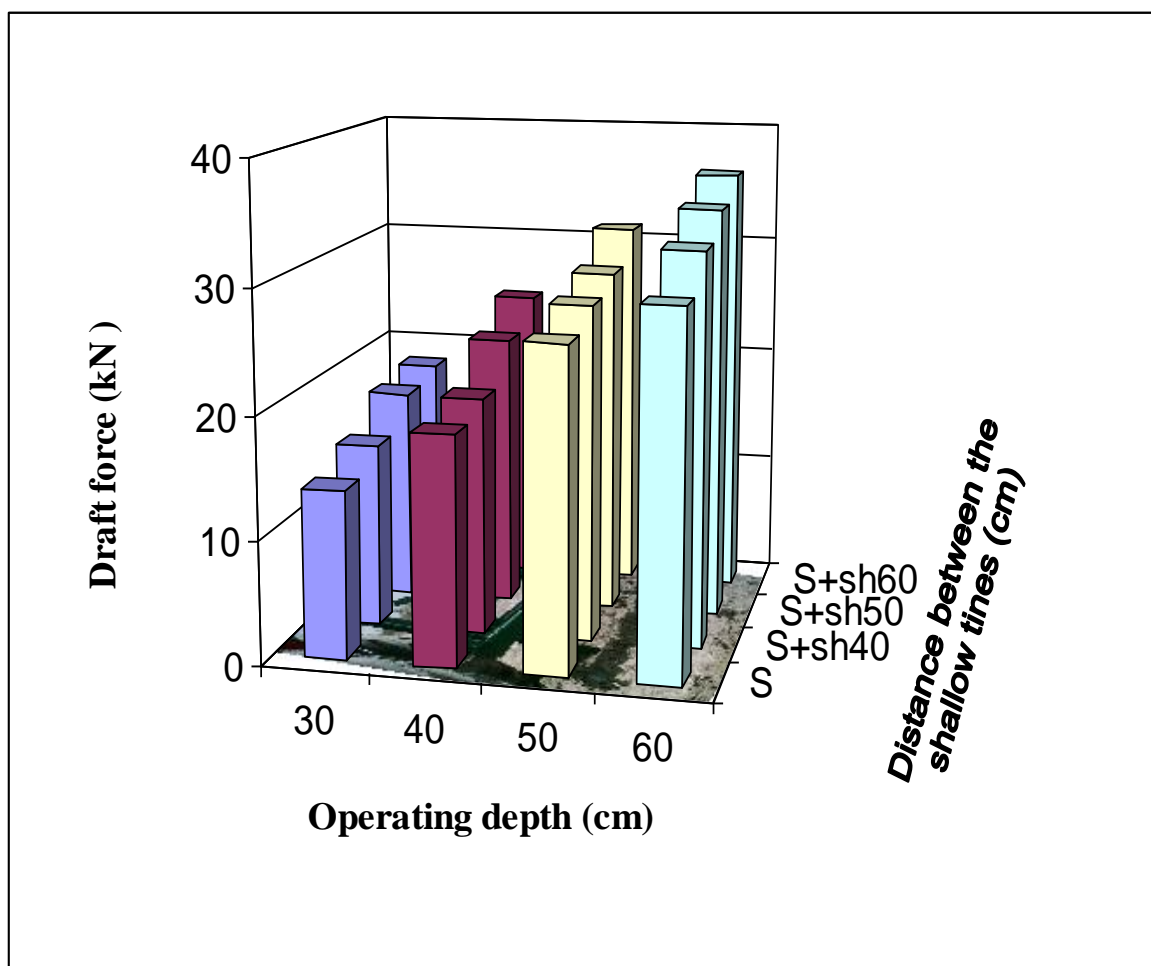

Figure (3): The draft force versus the operating depth for different lateral distance between the shallow tines.

3.3 The effect of the wings on the foot of the subsoiler on its draft requirement.

The addition of wings to the foot of the subsoiler increased the draft requirement of the subsoiler significantly ($p < 0.5$), figure 4. This can be related to the great volume of soil disturbed by the subsoiler, the increase in

the soil strength and the moisture content of the soil with depth (2). The draft requirement of the wings (on average) is 1.86kN. Adding wings to the shallow tines increased the draft force of the subsoiler further and that was because the wings increased the disturbed soil volume further.

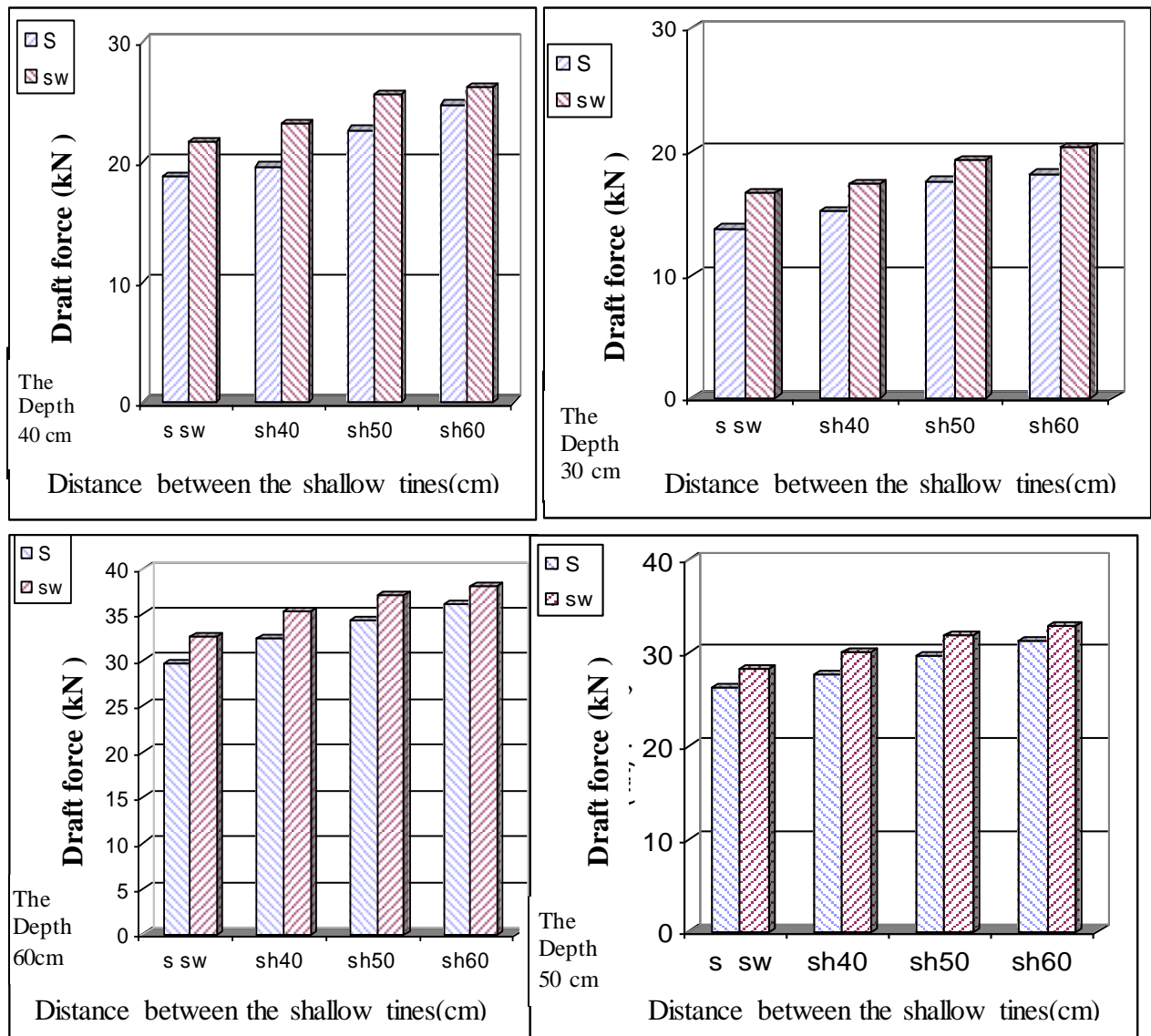

Figure (4): The draft force requirement of the subsoiler with wings versus the lateral distance between the shallow tines

3.4 The interaction effect of the lateral distance between the shallow tines, the wings on subsoiler foot and the operating depth on the draft force requirement

Increasing the operating depth and the lateral distance between shallow tines and adding wings to the subsoiler's foot increased the draft force

requirement of the subsoiler, figure 5. At the shallow operating depth of 30cm the draft requirement of SW is 15.2kN. When the operating depth increased to 60cm the draft requirement of SW increased to 24.3kN. When SW was proved with shallow tine at lateral distance 40cm (SW+sh40) the draft requirement increased from 24.3 to 31.6kN. When the operating depth increased to 60cm the draft force requirement of SW+sh60 increased to 38kN. The operating depth had greater effect on the draft force than the lateral distance and the lateral distance had greater effect than the wings. The operating depth increased the volume of the disturbed soil more than the other parameters and the soil moisture content and soil strength were higher at depth than the soil surface.

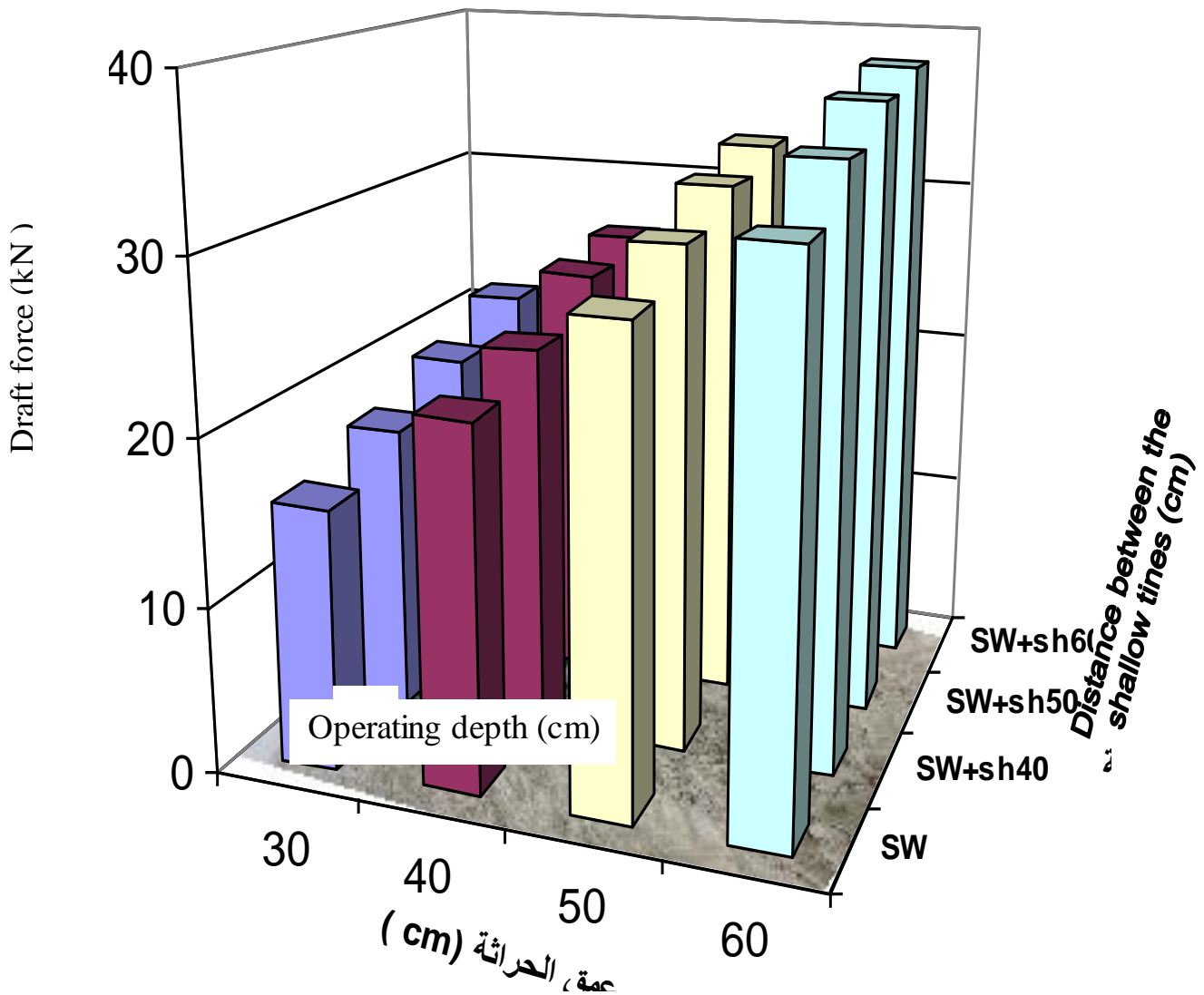

Figure (5): the draft force requirement versus the operating depth for different subsoiler combinations.

4.0 Conclusions

- (1) The draft force increased as the operating depth increased.
- (2) The draft force increased as the lateral distance between the shallow tines increased.
- (3) Using wings on the subsoiler foot increased the draft force requirement.
- (4) Draft force requirement of each centimeter of depth was 560N while for the lateral distance was 62N but increased to 92N with depth.
- (5) The most effective soil physical parameters on the draft force of the subsoiler are the soil cohesion and the bulk density while the moisture content was less effective.

Abbreviations:

S=subsoiler only: S+sh40= subsoiler+ shallow tines the distance between 40cm.: S+sh50= subsoiler+shallow tines the distance between 50cm.: S+sh60= subsoiler+ shallow tines the distance between 60cm.: S+W= subsoiler+ Wings

References

- 1-Aday, S.H., J. Abdulrahman and H. Al- Toblani (1993):
Determination the subsoiler critical depth and factors increasing deep loosening in heavy soils. Basra J. Agric. Sci. 6(2), pp 261-274
- 2 -Aday, S.H., and M. Hmood (1995): The field performance of the subsoiler when providing with wings and shallow tines in heavy soil. Mesoptamia, J. 7(4) 16-20.
- 3-Aday, S.H., and Y.Y. Hilal (2001): The effect of wings on the field performance of the subsoiler. The draft force and disturbed area. Basra J. Agric. Sci. 14(2), 79-94.
- 4- Aday. S. H. and Hilal, Y.Y. (2004). The effect of lifting angle of the subsoiler foot wings on its field performance in heavy soils. Iraqi J. Agric. 19(3): 195-207.
- 5- Aday, S.H., A.R. Al-Haliphy and A.R. Majeed (2004): Field study for a modified subsoiler draft requirement in a heavy soil. Iraq J. Agric. 9(2). 155-166.
- 6-Black, C. A.; Evans, D. D.; White, J. L.; Ensminger, L. E. and Clark, F. E. (1983). Methods of soil analysis. 6th ed., Am. Soc. Agron. Madison, Wisconsin, USA.
- 7-Gill and Vandenberg, G. E. (1968). Soil dynamics in tillage and traction. Agriculture Hand book, no. 316 Agric. Res. Service, U. S.

- 8-Godwin, R. J. (2007). A review of the effect of implements geometry on soil failure and implement forces. *Soil & Tillage Research* 97,331- 340.
- 9- Godwin, R.J.; Spoor, G. and Soomro, M.S., (1984). The effect of tine arrangement on soil force and disturbance. *J. Agric. Eng. Res.* 29, 47-56.
- 10-Manuwa, S. I. (2009). Performance evaluation of tillage tines operating under different depths in a sandy clay loam soil. *Soil & tillage Research* (103):399-405.
- 11- Mckyes, E. and Ali, O. S. (1977). the cutting of soil by narrow blades. *J. of Terramechanics* 2(14): 43-58.
- 12- Mckyes, E.(1984) Prediction and field Measurements of Tillage tool Draft forces and Efficiency in cohesive soils. *Soil & Tillage Research*,(4) 459-470.
- 13 Owen, G.T. (1988). Soil disturbance associated with deep subsoiling in compact soils. *Can. Agric. Eng.*, 30(1):33-37.
- 14- Raper, R. L. (2005). Force Requirements and Soil Disturbance of Straight and Bentleg Subsoiler for Conservation Tillage System. *Applied Engineering in Agriculture.* 21(5): 787-794.
- 15- Spoor, G. and Godwin, R.J. (1978). Experimental Investigation into the deep loosening of soil by rigid tines. *J. Agric. Eng. Res.* 23 (3): 243-258.
- 16-Wheeler, P. N. and Godwin, R. J. (1996). Soil Dynamics of Single and multiple tines at Speeds up to 20km/h. *J. Agric. Eng. Res.*, 63,243-250.

تأثير المسافة بين المحاريث الضحلة على متطلبات المحراث تحت سطح التربة من قوة السحب بالتربة الطينية الغرينية.

شاكر حنتوش عداي * مرتضى عبد العظيم عبد النبي * داخل راضي نديوي **

* قسم المكننة الزراعية ** قسم علوم التربة والموارد المائية / كلية الزراعة / جامعة البصرة

الخلاصة

صمم محراث تحت سطح التربة وزود بمحراثين ضحلين وضعا أمامه وبمسافة ٣٦ سم ويمكن التحكم بالمسافة بينهما ، كما زود المحراث تحت التربة بقدم يمكن إضافة أجنحة إليه عند مراحل التجربة. اختبر المحراث باستخدام أربعة أعماق وهي ٣٠ ، ٤٠ ، ٥٠ ، ٦٠ سم. وثلاث مسافات بين المحاريث الضحلة وهي ٤٠ ، ٥٠ ، ٦٠ سم وباستخدام أجنحة على قدم المحراث تحت سطح التربة وبدونها، ولأربعة تراكيب للمحراث وهي S و S+sh40 و S+sh50 و S+sh60 في تربة طينية غرينية (ثقيلة). أظهرت النتائج زيادة قوة السحب بصورة كبيرة مع زيادة العمق وتراوحت الزيادة من ١٥.٨٢ و ١٧.٨٨ للترايب الأربعة عند زيادة العمق من ٣٠ الى ٦٠ سم . وبلغت متطلبات السنتمتر الواحد من قوة السحب ٠.٥٦ kN (٥٦٠ N = ٥٧.١ kg) كما زادت قوة السحب مع زيادة المسافة بين المحاريث الضحلة ولكن بمقدار اقل مقارنة مع العمق وبلغت متطلبات السنتمتر الواحد من المسافة بين المحاريث الضحلة من قوة السحب ٠.٠٩١ (٩١ N = ٩.٣ kg) وهي اقل من تلك للعمق الكبيرة. وأدت إضافة الأجنحة إلى العمق إلى زيادة قوة السحب وخصوصا مع الأعماق الكبيرة. وأظهرت النتائج أن أعلى متطلبات لقوة السحب سجلت للعمق ٦٠ سم والمسافة بين المحاريث الضحلة ٦٠ سم وعند إضافة الأجنحة.